

HAG-4415 4" Air Angle Grinder

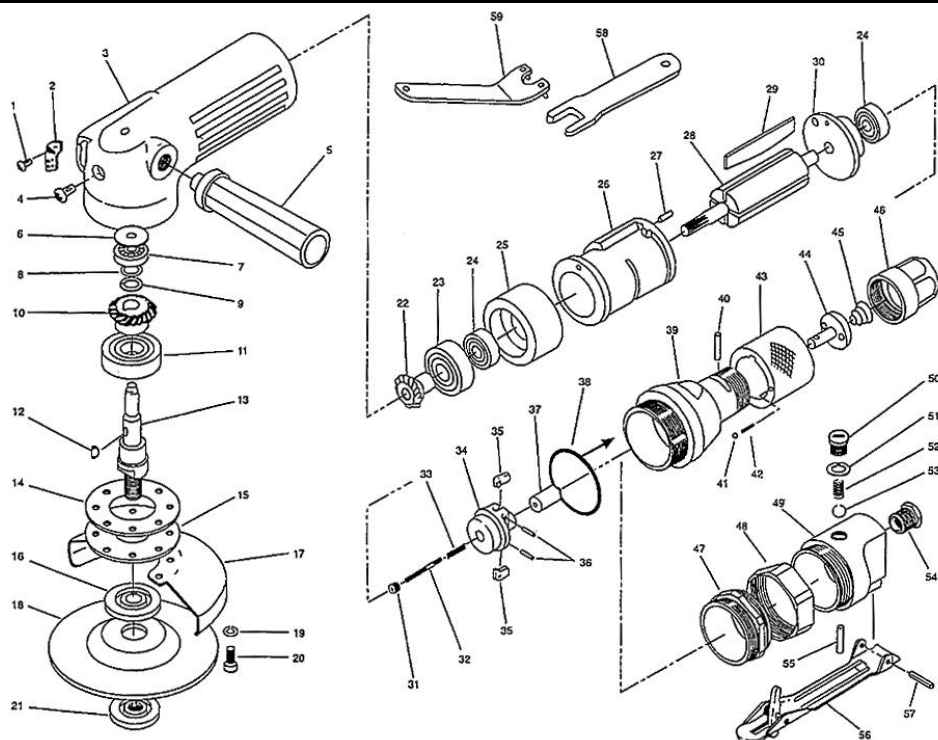

PART LIST

NO.	PARTS NAME (ENG)	Q'T Y
1	Screw (3*6)	2
2	Deflector	1
3	Motor Housing	1
4	Screw (M6*8)	1
5	Dead Handle	1
6	Spacer	1
7	Ball Bearing (626)	1
8	Retaining Ring (C-10)	1
9	Wave Washer (W-10)	1
10	Bevel Gear	1
11	Ball Bearing (6202ZZ)	1
12	Key (3*13)	1
13	Spindle	1
14	Gasket	1
15	Retainer	1
16	Disc Receiver For 16mm Hole	1
17	Disc Cover	1
18	4" Disc 16mm Hole	1
19	Washer (M5)	4
20	Cap Screw (M5*15)	4
21	Disc Nut	1
22	Pinion Gear	1
23	Ball Bearing (6201ZZ)	1
24	Ball Bearing (608)	2
25	Front Plate	1
26	Cylinder	1
27	Roll Pin (3-6 mm)	1
28	Rotor	1
29	Rotor Blade	4
30	Rear Plate	1

NO.	PARTS NAME (ENG)	Q'T Y
31	Adjust Nut (M2)	1
32	Adjust Screw	1
33	Governor Spring	1
34	Governor	1
35	Pendulum	6
36	Roll Pin (3-12mm)	2
37	Plunger	1
38	O-Ring	1
39	Governor Case	1
40	Valve Pin	1
41	Steel Ball	1
42	Valve Spring	1
43	Valve Ring	1
44	Valve	1
45	Conical Spring	1
46	Inlet Bushing	1
47	Lock nut	1
48	Coupling Nut	1
49	Valve Housing Incl. Valve Bush	1
50	Valve Screw	1
51	O-Ring	1
52	Valve Spring	1
53	Valve	1
54	Inlet Bushing	1
55	Valve Pin	1
56	Throttle Lever	1
57	Roll Pin	1
58	Spanner	1
59	Pin Wrench	1

Consumable parts No. 7, 10, 22, 23, 24, 26, 29